

Nurse Call Monitoring System **POWERHOUSE™**

**For health care centers
who care for their patients**

Power House offers the latest solid state call indication and monitoring system most suitable for **Hospitals and Nursing Homes**. The system is designed with utmost reliability, dependability and safety features in mind. This unique system replaces the conventional system and offers many added features.

The Conventional system:

A patient is provided with a call push button switch. The buzzer at the nurse's room sounds and indicator is lighted up. The attendant or the nurse re-sets the call there and then go to attend the patient.

There are chances of **negligence** at every step and the system does not have any safety or monitoring feature. Some of the important dangers/ lacunae :

- 1: The patient is exposed to dangerous 220 V. AC through push button switch.
- 2: The patient is at the mercy of attendant who can re-set the call without going to the patient.
- 3: In case of power cut, the patient has no means to call for help.

Power House nurse call indication and monitoring system overcomes all the above points. It adds many advantages for the management to provide better services to their patient.

Added Features:

Low voltage operation:

The incoming mains is converted to 12 V.D.C. in the Power Supply section and patient is not put to danger even due to accidental snatching of wires.

Battery backup:

To facilitate making call even during power cut, the system is provided with a battery backup.

Detachable call PUSH:

Call points are made of soft push buttons with flexible cord and detachable plug.

Re-set at patients bed:

To re-set, the nurse or attendant has to press a button installed near the patient. This ensures attendance.

Built in timer:

Each call received activates a built in timer and after a specified time, it triggers a separate buzzer to draw attention of Matron. The buzzer is silenced only after attending the patient.

Un-attended Call:

Through change of color of indicators (green to red) Matron will identify the unattended call.

Soft Buzzer:

System incorporate soft tone buzzer to ensure no disturbance in the hospital/ nursing home.

Compact and flexible:

The system requires very low space and is flexible to add on as the number of beds increases. Marking on he indication board can be custom designed for easy location and is editable.

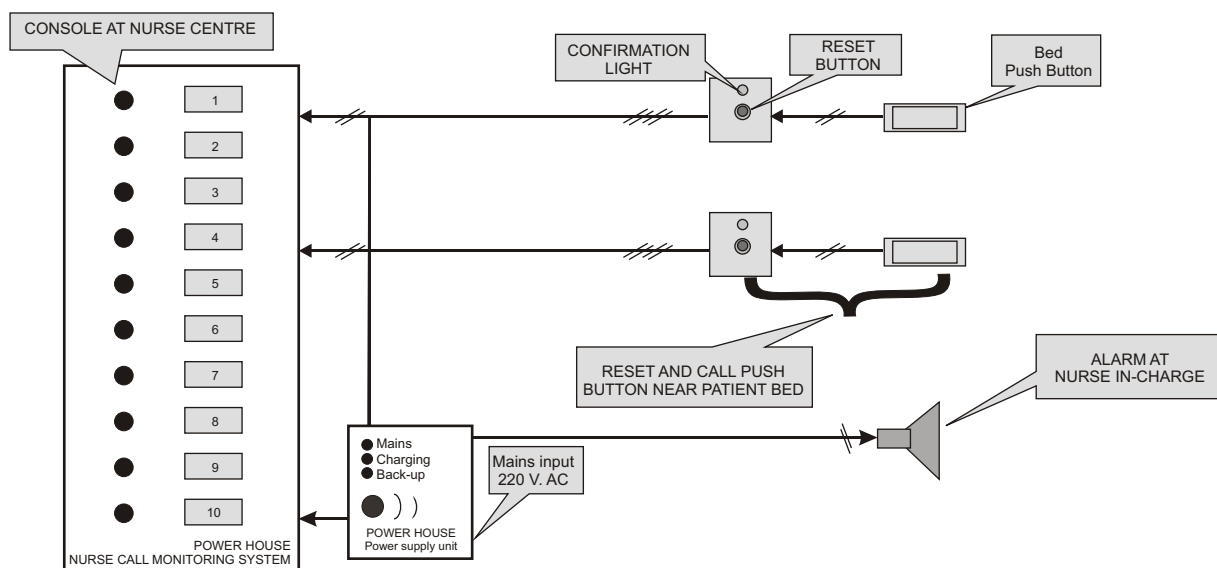

POWER SERVICES
Innovative Power Solutions

33, Phears Lane, Kolkata -700 073
Ph./Fax (033) 2237-0508, 2236-0575.
Email: info@indiapowerhouse.net
Visit us at www.indiapowerhouse.com